

Design and Application of Intelligent Classroom in English Language and Literature Based on Artificial Intelligence Technology

Kehan Du¹ 

Abstract

"English Language and Literature" courses are essential components of university education. They provide a significant avenue for understanding the politics, economics, and customs of English-speaking countries. These courses facilitate a mastery of English grammar, which in turn enhances students' comprehension of spoken and written English content. However, traditional modes of instruction in English Language and Literature often lack engagement and interactivity, thereby limiting the effectiveness of learning in this field. In order to boost learners' interest and efficiency in studying English, it is imperative to shift away from conventional teaching approaches. With the rapid advancement of artificial intelligence in various domains, its integration with English Language and Literature education can yield intelligent learning experiences. This study employs a combination of Convolutional Neural Networks (CNN) and Gated Recurrent Units (GRU) to reform the teaching model in English Language and Literature. The results indicate that CNN and GRU methodologies offer substantial support in realizing intelligent approaches to teaching this field. These methods exhibit a high degree of similarity and accuracy in predicting linguistic features in English Language and Literature. They excel in terms of predictive and scatter error distribution, showcasing superior performance.

Keywords: English language and literature, smarter classroom, artificial intelligence, CNN, gate recurrent unit

Received: 17 March 2022

Received in revised form: 24 August 2022

Accepted: 28 August 2022

¹ Corresponding Author: School of International Education, Henan University of Engineering, Henan Province, China, 450000;

ORCID ID: <https://orcid.org/0009-0001-1115-1838>; Email: dkh112@126.com

1. Introduction

English Language and Literature education is a crucial major course in universities, primarily focused on analyzing the background, emotions, and plot of English literature. Through studying English language and literature, students can gain a comprehensive understanding of the linguistic context and English expression (Dalvai, 2019; Genova, 2019; Hu & Wang, 2023; Wang & Hemchua, 2022). English Language and Literature education also represents an early English language curriculum in our country, primarily imparting knowledge about the origins, societal, economic, and political cultures of the English language (Derakhshan & Shakki, 2020). This education aims to guide students in grasping the genuine linguistic context behind English, which in turn aids English majors in gaining a more comprehensive understanding of the intricate English backdrop and further enhancing their skills in listening, speaking, reading, and writing in English (Arsyad & Adila, 2018; Sargsyan & Zimina, 2021; Wang et al., 2023a). Chinese language often guides students in understanding China's developmental history through mediums such as novels, poetry, and classical Chinese texts. Through this educational approach, students can grasp the essence and developmental background of the Chinese language, which also aids them in comprehending the true origins of Chinese and aspects related to audio-visual aspects. English Language and Literature can play a similar role to Chinese novels, poetry, and classical texts. English major students, by studying English Language and Literature, develop a deeper retention of audio-visual knowledge in English. The development of English shares similarities with the development of Chinese. The formation of a language undergoes historical and evolutionary trials. The existing characteristics of a language are significantly linked to its history, customs, and traditions (Bai, 2020; Torralbo, 2021; Wang et al., 2022a). Therefore, English major students can learn through English Language and Literature. The role of English Language and Literature is akin to Chinese poetry; it chronicles the evolution of linguistic traits and characteristics throughout the history of English-speaking countries. To truly understand a language, one must grasp its origins and developmental history to comprehend its essence. In general, English Language and Literature encompass aspects such as history, novel plots, political economy, and society, among others (Dunn & Johnson, 2020; Vilaco & Guirau, 2019; Wang et al., 2022b; Wang & Derakhshan, 2023). To understand a country's political, economic, and social development, it is essential to comprehend its history of political and economic progress. News also serves as a

common means, but it's often hindered by factors of confidentiality. Learning English Language and Literature not only equips individuals with language knowledge relevant to audio-visual comprehension but also offers insights into the history, economy, and political development of English-speaking nations. In doing so, it facilitates an understanding of both the knowledge and pronunciation specific to these countries, thereby minimizing misunderstandings in English conversations. In short, English Language and Literature are pivotal courses for grasping the politics, economics, and human development of English-speaking nations. The fact that many universities offer education in English Language and Literature underscores the significance of this subject.

For middle school or university students, English courses themselves tend to be dull, largely due to the focus on fundamental grammar and sentence structures. However, grammar and sentence structures are essential foundational knowledge for comprehending spoken and written English, much like the importance of Pinyin and basic sentence construction in Chinese. Making English lessons engaging and interesting has long been a significant concern for researchers in the field of English language education (Derakhshan, 2022; Marinaro, 2020; Rivera, 2018; Shakki, 2023; Wang & Derakhshan, 2023; Wang, 2023). It requires not only the acquisition of fundamental English knowledge but also the understanding of English customs and other related information. Ensuring vibrancy and engagement within English courses is crucial (Al-Obaydi, Shakki et al., 2023; Shakki, 2022). When a course is lively and interesting, it ensures the efficiency of learning. Such an environment also sparks creativity in teachers (Wang & Pan, 2023; Wu et al., 2023; Yüce et al., 2023; Zhi & Wang, 2023). The limitations of traditional teaching models have hindered the progress of English Language and Literature education. Conventional classrooms often rely heavily on textbook and PowerPoint-based explanations for English Language and Literature content, resulting in monotony. Hence, a new type of technology needs to be introduced to assist in teaching English Language and Literature courses (Al-Obaydi, Pikhart et al., 2023). This approach not only imparts relevant knowledge to students but also enhances their interest. It necessitates the integration of smart classrooms into English literature education (Derakhshan & Shakki, 2019; Hu et al., 2022; Pedersen et al., 2022).

The integration of artificial intelligence technology with English Language and Literature teaching courses can enhance the intelligence of English Language and

Literature education (Derakhshan & Fathi, 2023; Ding & Hong, 2023; Fu & Wang, 2022; Guo et al., 2023; Wang et al., 2023b, 2023c). Artificial intelligence technology has been under development for many years, but due to limitations in computing power, it has often faced stagnation. In recent years, rapid advancements in computer performance have propelled the swift progress of artificial intelligence technology. Various countries have also prioritized the development of intelligence technology as a crucial measure. Artificial intelligence technology has the potential to be integrated with every field, thereby elevating the efficiency and intelligence of each domain of work (Guo et al., 2018; He et al., 2019). If work possesses intelligence, it will enhance the efficiency of both work and learning. With the development of artificial intelligence technology, many mature algorithms have emerged. Convolutional Neural Networks (CNN), Long Short-Term Memory (LSTM), and Reinforcement Learning (RL) are three relatively mature algorithms, and their variants have been widely applied across various domains. CNN is primarily used for feature extraction, while LSTM algorithms are employed to capture temporal features of the subject of study. Reinforcement learning is an algorithm highly reliant on the environment.

This study will leverage artificial intelligence technology and employ CNN and GRU methods to realize an intelligent classroom for teaching English Language and Literature. GRU, which is a variant of the LSTM method, is also widely utilized in various time-related domains. This research will present the implementation of an intelligent classroom for English Language and Literature through five aspects. The first section primarily emphasizes the significance of English Language and Literature and the historical development of artificial intelligence technology. The second section outlines the current state of research in English language education. The third section investigates the implementation of intelligent teaching within English Language and Literature classrooms. The fourth section analyzes the predictive accuracy of CNN and GRU methods concerning relevant features in intelligent English Language and Literature courses. The fifth section describes and summarizes the entirety of the research and methodology.

2. Related Research

English grammar and syntax are the primary focal points in English Language and Literature or English language teaching. A better understanding of these

fundamental aspects aids in the more effective learning and exploration of content related to English Language and Literature. Due to the significance of English language learning and studying English Language and Literature, numerous researchers have conducted extensive studies in this area. Li (2019) utilized Bayesian methods to investigate the computational accuracy of factors related to English Language and Literature. This approach mainly addresses the issue of poor computational accuracy in traditional Bayesian methods. By employing a multi-layer Bayesian computational mechanism in conjunction with the traditional Bayesian algorithm, the study compared the application of these two algorithms in calculating features of English Language and Literature. The results revealed that the new Bayesian computational mechanism exhibited higher accuracy in calculating relevant features of English language and literature. Zhao (2018) found that even during periods of political upheaval, English Language and Literature education did not come to a halt, underscoring the importance of English Language and Literature. The study explored the impact of English Language and Literature and English communication on the development of Chinese literature. It specifically investigated English Language and Literature education in China, discovering that it heightened students' interest in English learning. Diversified English Language and Literature education also facilitated the development of contemporary translation and theoretical research. Razavipour et al. (2018) have suggested that high-stakes English exams drive the development of both students' and teachers' English courses. Their study explored the application of the backwash effect in English teaching, examining students' learning characteristics and test-taking attitudes. The research utilized data from 100 students and teachers in Iranian universities, employing descriptive statistics and t-tests to validate the backwash effect. The findings indicated that the testing approach influences students' attitudes towards English language and literature. Hart (2019) contends that form, context, and language are significant attributes of English Language and Literature. The study primarily delved into the relationship and distinctions between English Language and Literature and English poetry, particularly exploring the development of English poetry before the unification of England. English poetry, or English Language and Literature, encompasses a wealth of cultural and linguistic influences from English-speaking nations. The historical development and attributes of English Language and Literature or English poetry can be understood through these mediums, also revealing differences between English and Chinese poetry. The conclusion underscores that

English literature or English poetry is of paramount cultural importance, meriting further research and understanding by scholars. Chen et al. (2022) argue that issues within English language pose constraints on the development of the English major. They devised a novel teaching approach using big data technology and online English learning platforms. This model primarily employs BP neural networks to enhance the level of English Language and Literature education. They contend that English Language and Literature education will improve students' abilities for cross-cultural communication and aid in distinguishing and studying various literary works. The English Language and Literature learning system leverages data mining techniques to extract relevant knowledge from massive datasets, thereby boosting the efficiency of English Language and Literature learning. Guan (2018) also observes that with the advent of economic globalization and integration, the teaching model for English Language and Literature can no longer be confined to traditional methods. This places higher demands on the teaching methodologies and quality of English Language and Literature. The present study delves into cross-cultural awareness in learning English Language and Literature, exploring its significance and implications within education. Despite the numerous researchers who have investigated various aspects of English Language and Literature, the fusion of English Language and Literature with artificial intelligence remains relatively unexplored. This study employs artificial intelligence methods to realize an intelligent classroom model for teaching English Language and Literature.

3. Application of CNN and GRU Technology in English Language and Literature Wisdom Course

3.1. The Significance of AI Technology for Realizing Intelligent English Language and Literature Classrooms

The realization of an intelligent English Language and Literature teaching classroom requires a certain level of intelligence, necessitating the integration of artificial intelligence technology. Artificial intelligence technology can assist in automating the study of subjects. It has the capability to learn features from vast datasets and subsequently make decisions and judgments in unfamiliar situations. (Davies & Buzacott, 2022). This research employed the CNN and GRU algorithms. CNN is a common method for feature extraction, while GRU is a prevalent variant of LSTM and is suitable for capturing temporal data in English

language and feature extraction. Once the relationship between relevant features in English Language and Literature teaching is comprehended through artificial intelligence, intelligent teaching can be achieved. Without the methods of artificial intelligence, attaining intelligence in English Language and Literature education would be challenging. By referencing numerous successful cases, it becomes apparent that the intelligence of the subject of study is involved and necessitates the intervention of artificial intelligence methods.

3.2. The Design Process of Smart English Language Course and the Introduction of GRU Algorithm

The objective of this study is to achieve the intelligence of English Language and Literature classrooms by uncovering the relationship between linguistic, syntactic, and emotional features of English Language and Literature and intelligent teaching. Many data serve as the foundation for artificial intelligence methods. By acquiring large datasets, correlations between inputs and outputs can be identified. Inputs and outputs refer to the relationship between features of the subject of study and the desired outcomes. This research will establish connections between student speech, syntax, emotional features of English Language and Literature, and intelligent course design. Figure 1 illustrates the design scheme of employing CNN and GRU methods to achieve intelligent English Language and Literature teaching. The dataset has been collected and preprocessed, and it can be directly utilized by the CNN and GRU algorithms. As depicted, the framework primarily consists of input layers, CNN and GRU layers, and output layers. The foundational theories of CNN and GRU are detailed in Sections 3.2 and 3.3 respectively. The input layer will process English feature data, while the output layer can handle the anticipated feature data. CNN and GRU will utilize weights and biases to extract feature relationships. Initially, data values of student speech, syntactic features, and emotional features of English Language and Literature will serve as input data for CNN. CNN will comprehensively extract features relevant to intelligent courses from these three categories of data. The output data of CNN will be directly fed into the GRU method, which will further extract temporal characteristics of this data and the intelligent course. Once the CNN and GRU models are trained, they can showcase relevant knowledge of English Language and Literature to students or teachers through a computer-assisted system, serving

as a feedback mechanism.

Figure 1

The Application of CNN and GRU Methods in Intelligent English Language and Literature Teaching

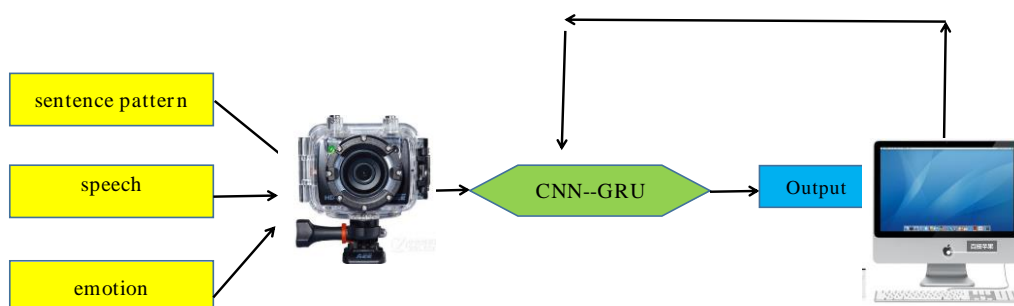

Despite LSTM's ability to retain longer-term memory, enabling it to better remember historical information and maintain some continuity and relevance with future information, it has certain limitations. For instance, a person's sentence not only relates to their immediate mental state but could also have a greater correlation with historical weather and emotions. Considering the speech patterns of students and the syntactic characteristics of English Language and Literature, introducing time-related artificial intelligence algorithms is necessary. The major drawback of the LSTM algorithm is its significantly larger number of computational parameters, demanding greater computational resources and time. This restricts the application of LSTM technology, leading researchers to develop a GRU-based time feature extraction method to mitigate the computational complexity of parameters. In comparison to LSTM, this approach involves fewer parameter computations. Figure 2 illustrates a computational diagram of the GRU method, which, compared to LSTM, has undergone certain structural improvements.

Figure 2
The Working Principle of the GRU Method

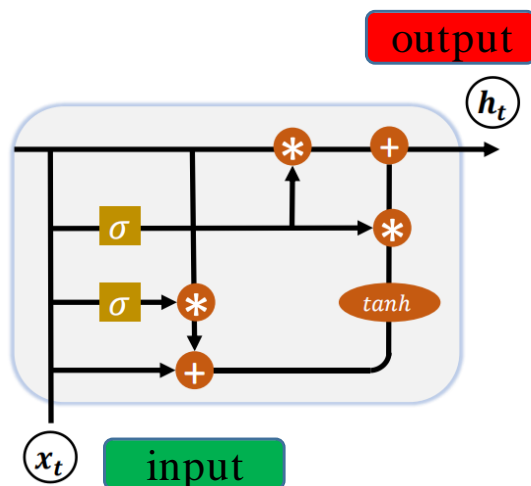

3.3. Introduction to Main Equations and CNN Algorithm

The frequency of CNN is higher compared to GRU. This study primarily utilizes CNN to extract sentence patterns, emotional aspects of English Language and Literature, and the non-linear relationship between student speech features and intelligent teaching classrooms. GRU's inputs and outputs are time series data, capable of establishing temporal relationships. However, to achieve an intelligent English Language and Literature classroom, the introduction of CNN is also necessary. CNN's advantage lies in its ability to handle large volumes of data, and in comparison, to LSTM, it has a relatively lower computational load. This reduction in computational resource utilization enhances computational efficiency. Figure 3 illustrates the computational method and process of CNN.

The deep learning model for English literature education consists of both the training process and the testing process, as illustrated in Figure 4. The dataset of the testing set is directly offset with the optimal weights from matrix calculations. The data preprocessing process standardizes all data between 0 and 1, ensuring they adhere to a normal distribution. This aids the iterative process of the deep learning model, expediting convergence speed. In this study, CNN and GRU algorithms are employed as the deep learning models. CNN has found extensive applications in areas such as image recognition and transportation, boasting significant advantages in processing spatial features of data. It conveniently

employs filters, different channels, and weights to map the non-linear relationships between input and output data. GRU has been utilized in fields like speech recognition and time-series wind power prediction, enabling it to use forget gates, memory gates, and update gates to remember relationships between historical and current temporal information. In comparison to the traditional LSTM, GRU has a stronger data processing capability, which reduces its gate structure to two. Learning English Language and Literature involves both spatial and temporal features within a substantial dataset. Both CNN and GRU are supervised learning methods that require a dataset with input and output data. However, the input and output data of GRU are in the form of time series, which can be viewed as beneficial for the iterative learning of CNN first, followed by the promotion of learning and iterative time features for GRU. In the deep learning approach, the testing set no longer undergoes the iterative process. The testing set data is directly subjected to matrix calculations using optimal weights and biases, yielding corresponding test results. This process is relatively efficient and accurate.

Figure 3
The Working Principle of the CNN Method

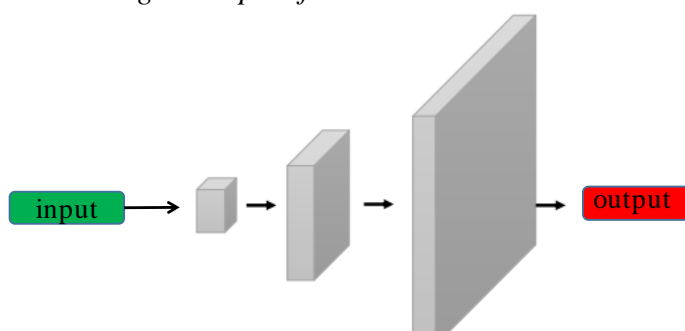
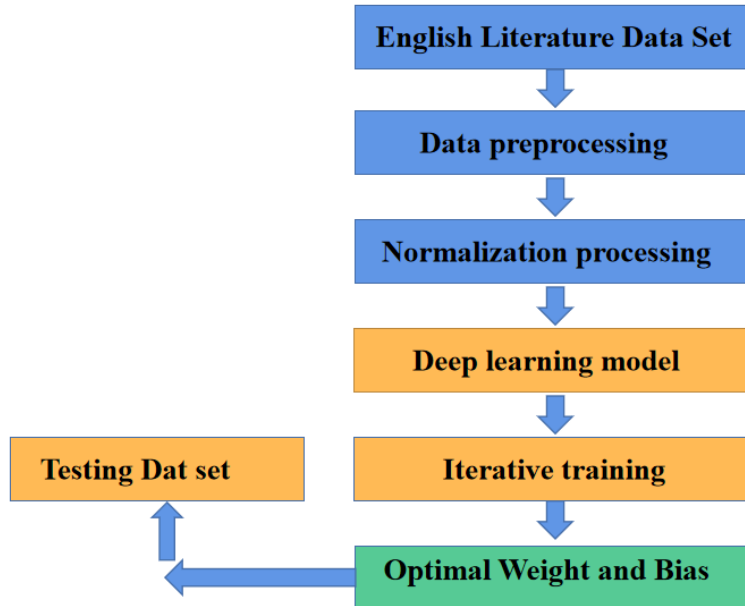

Figure 4
Detailed Calculation Process of Theoretical Framework



CNN also possesses certain feedback and propagation mechanisms. The driving force is to minimize the derivatives of weights and biases. As a result, the computation process of CNN involves a chain of derivative operations. Equations 1 and 2 illustrate the computational standards used for deriving weights and biases within a hidden layer.

$$\Delta\omega_{ji} = -\eta \frac{\partial E}{\partial \omega_{ji}} \quad (1)$$

$$\Delta u_{ij} = -\eta \frac{\partial E}{\partial u_{ij}} \quad (2)$$

Error computation serves as the driving force for gradient descent, a technique that aims to locate the point of minimum gradient by evaluating the value of the loss function. Equation 3 demonstrates one method for calculating the loss function.

$$E = \frac{1}{2} (d_{out} - O_{real})^2 = \frac{1}{2} \sum_{\kappa=1}^t (d_{\kappa} - O_{\kappa})^2 \quad (3)$$

Equation 4 shows a calculation method of weights and biases in the hidden layer, which is also a manifestation of the chain algorithm.

$$E = \frac{1}{2} \sum_{k=1}^m [d_k - f(\text{net}w_k)]^2 = \frac{1}{2} \sum_{k=1}^m [d_k - f(\sum_{j=0}^n \omega_{jk} y_j)]^2 \quad (4)$$

Equation 5 shows the calculation method of the CNN input layer, which involves the convolution operation and the weight sharing mechanism.

$$a^2 = \sigma(z^2) = \sigma(a^1 * W^2 + b^2) \quad (5)$$

Neural networks will incorporate activation functions, which form the nonlinear foundation. Equation 6 illustrates how to compute the activation function in both CNN and GRU.

$$a^l = \text{Re } LU(z^l) = \text{Re } LU(W^l a^{l-1} + b^l) \quad (6)$$

The biggest difference between GRU and LSTM is that GRU only has two gate structures, which are update gate and reset gate. This reduces the amount of parameter computation. Equation 7 and Equation 8 show how the reset gate is calculated. It will control the amount of historical state and the amount of current state.

$$g_r = \sigma(W_r[h_{t-1}, x_t] + b_r) \quad (7)$$

$$\tilde{h}_t = \tanh(W_h[g_r h_{t-1}, x_t] + b_h) \quad (8)$$

Equations 9 and 10 demonstrate the calculation process of the update gate in GRU. The update gate controls the input level from the previous time step as well as the input level influenced by the new input. The quantity of updates will be in a competitive state.

$$g_z = \sigma(W_z[h_{t-1}, x_t] + b_z) \quad (9)$$

$$h_t = (1 - g_z)h_{t-1} + g_z \tilde{h}_t \quad (10)$$

4. Result Analysis and Discussion

This study utilized artificial intelligence technology to implement an intelligent classroom for English Language and Literature. English Language and Literature encompass numerous features, and for the purpose of this research, student speech

features, sentence patterns of English Language and Literature, and the emotional aspects of both were selected as the study's subjects. These three characteristics have a significant impact on the realization of an intelligent classroom for English Language and Literature. English Language and Literature comprise vast literary databases, making it challenging for English learners to find relevant materials of interest. Once a more intelligent classroom for English Language and Literature is established, it will automatically match content based on students' speech and emotional characteristics. This not only enhances the quality of teaching but also offers a more beneficial instructional model for both teachers and students. This study selected relevant data from multiple universities in Beijing that exhibit distinct characteristics of English Language and Literature. Beijing not only hosts numerous universities but also possesses abundant resources in English Language and Literature. The availability of datasets featuring various English language and literary characteristics benefits the training of CNN and GRU models.

The primary function of GRU is to extract sentence patterns and temporal characteristics of student speech from English Language and Literature. GRU serves a similar purpose as LSTM, enabling better extraction of temporal features from the subject of study. To validate the role of GRU in English Language and Literature, this study first analyzed the accuracy of algorithms without GRU in predicting relevant features in English Language and Literature. Figure 5 illustrates the average errors in predicting three features within the intelligent classroom for English Language and Literature, when GRU is not incorporated. Despite these three features' prediction errors falling within the desired maximum error range, their distribution of errors is relatively broad. This might be due to incomplete feature extraction by CNN while predicting characteristics of the intelligent classroom for English Language and Literature, leading to a relatively larger spread of errors. The prediction errors for these three features all exceed 2%, with the maximum error even exceeding 2.8%, which is unfavorable.

Figure 5

Prediction Error of Three Features of English Language and Literature Smarter Classroom Using an Algorithm Without GRU

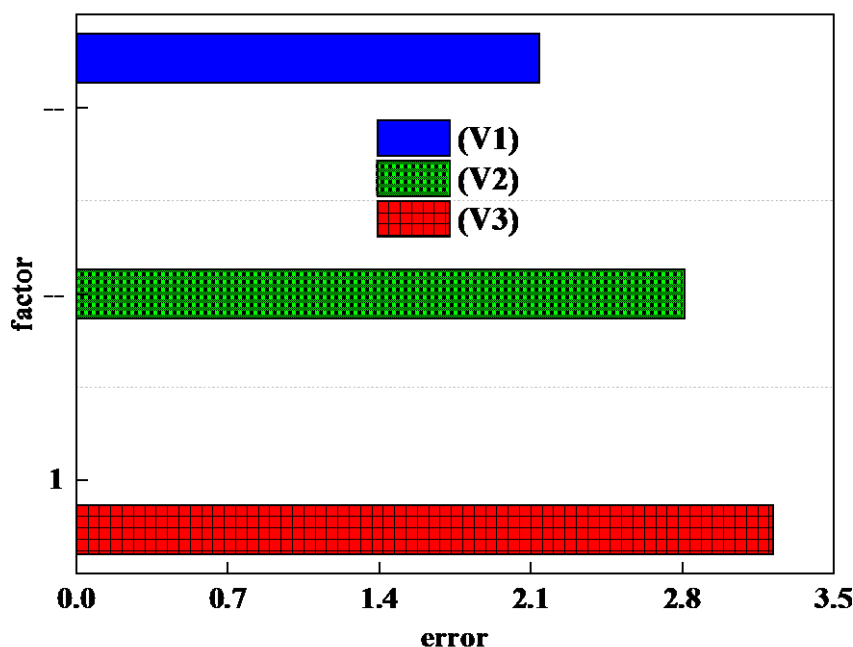
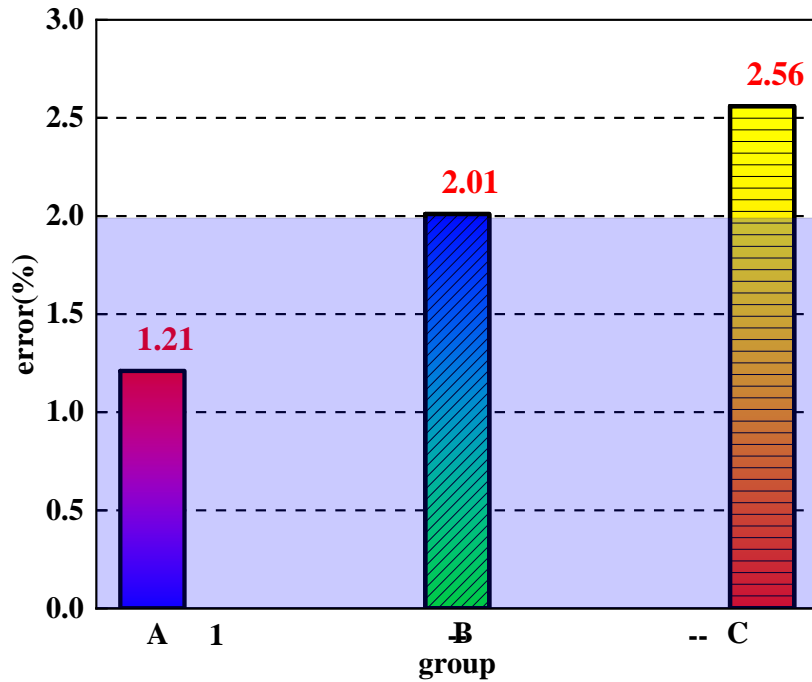

Figure 6 depicts the distribution of prediction errors for the intelligent classroom of English Language and Literature using the GRU algorithm. GRU performs better in handling temporal features. From Figure 6, it can be observed that a hybrid algorithm employing both CNN and GRU has been applied. This hybrid approach not only accomplishes the extraction of temporal features but also maps non-linear relationships. Clearly evident from Figure 6, the errors in all three aspects of the intelligent classroom for English Language and Literature have significantly decreased, indicating the advantages of GRU technology in extracting student speech characteristics, English Language and Literature sentence patterns, and emotional temporal features. This technology ensures a relatively comprehensive extraction of these three features. In Figure 6, 'A' represents student speech characteristics, 'B' represents sentence patterns in English Language and Literature, and 'C' represents the emotional nature of student speeches. As can be observed from Figure 5, the largest reduction occurs in segment 'A'. The error rate drops from around 2% to 1.21%.

Figure 6

Prediction Errors of Three Characteristics of English Language and Literature Smarter Classroom Using an Algorithm Containing GRU



This indicates that student speech contains more significant temporal features, prompting the application of GRU technology in the intelligent classroom. The prediction error for feature 'C' also experiences a substantial decrease, yet it remains at a relatively high error level of 2.56%. This suggests that emotional features in English Language and Literature are part of this aspect.

Figure 7

Error Distribution of Students' Speech Characteristics in English Language and Literature Wisdom Classroom

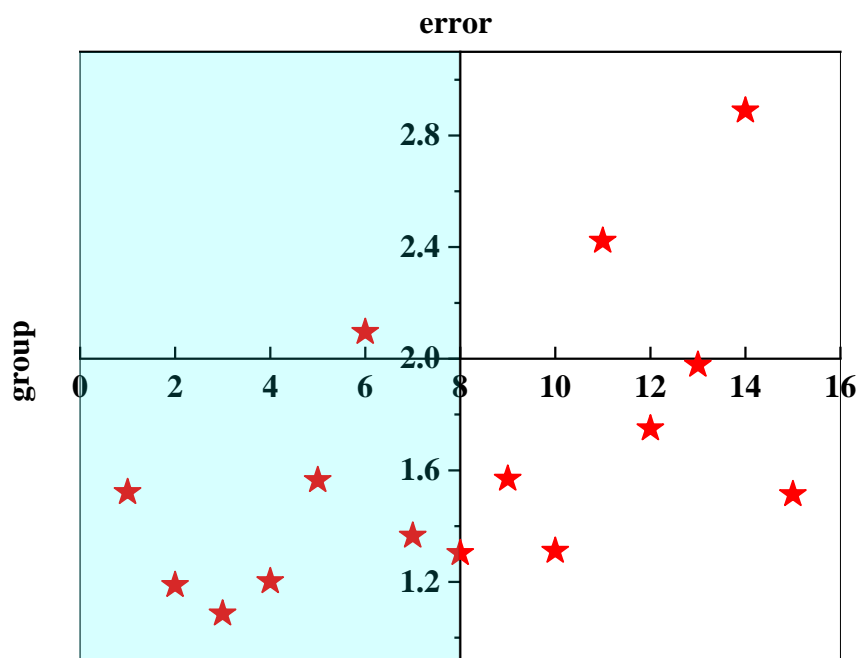

To further validate the accuracy of GRU and CNN algorithms in predicting the intelligent classroom's linguistic features of English Language and Literature, this study selected 15 sets of student speech data for further verification. Figure 7 displays the distribution of prediction errors for student speech features. Data points with prediction errors less than 2% are distributed below the x-axis, whereas they are above the x-axis. From Figure 7, it can be observed that the majority of prediction error points are distributed below the x-axis, indicating that most of the student speech feature errors are within 2%. Only a few points are above the x-axis. The maximum prediction error for student speech features is also within 3%, which is just a single data point. Overall, the CNN and GRU methods are highly favorable algorithms for achieving an intelligent classroom in English Language and Literature.

Sentence patterns are also a crucial feature of English Language and Literature. Understanding students is key to comprehending the essence of English Language and Literature. Figure 8 displays the linear correlation distribution of predicted sentence pattern features in English Language and Literature. Linear correlation is a form of accuracy, distinct from error. It also shows the relative magnitude of

predicted and actual values for sentence patterns. The red line represents a confidence level exceeding 95%. It can be observed that most data points are distributed on both sides of the linear function of sentence pattern features in English Language and Literature. This suggests significant success in predicting the sentence pattern features of English Language and Literature using the GRU and CNN methods. This is also beneficial for realizing an intelligent classroom for English Language and Literature. All data points fall within the 95% confidence interval, indicating that the accuracy can reach up to 95%.

Figure 8

Linear Correlation of Sentence Pattern Features in English Language and Literature Wisdom Classroom

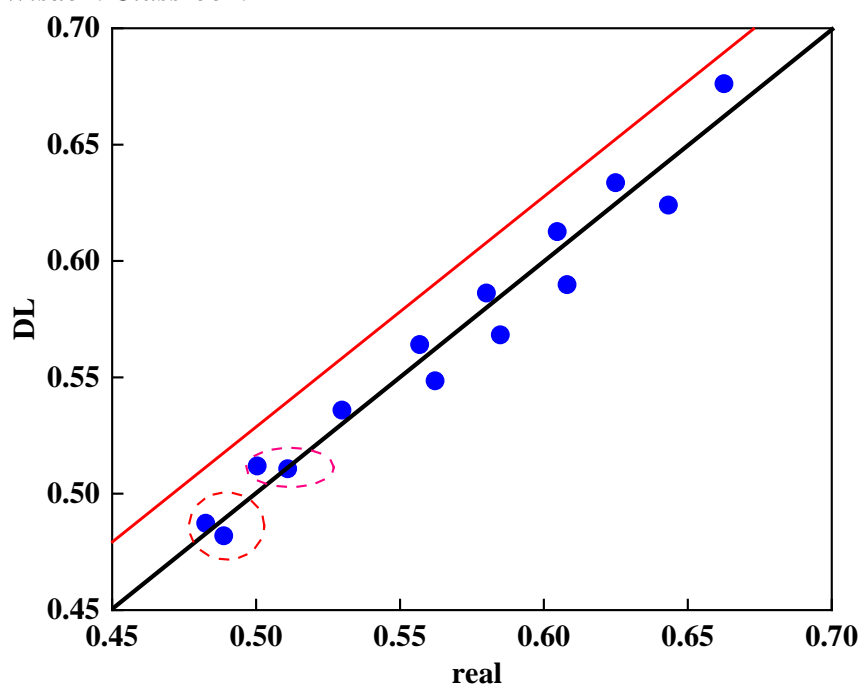

The prediction error for emotional features in English Language and Literature is the largest among all the features in previous studies. The emotional features expressed in English Language and Literature represent the sentiments conveyed by writers regarding political and economic aspects. This aspect requires English learners to study and experience. These emotional features are more challenging for different learning groups to grasp. Figure 9 displays the distribution of predicted values for emotional features in the intelligent classroom of English

Language and Literature. The yellow region represents the distribution of prediction errors for emotional features. Overall, the CNN and GRU methods exhibit relatively consistent errors in predicting the emotional features of English Language and Literature. Although this section of errors is relatively larger, it shows a good distribution uniformity. Given that extreme error conditions are absent, this type of error is considered acceptable.

Figure 9

Predictive Distributions of Affective Traits in Smart Classrooms in English Language and Literature

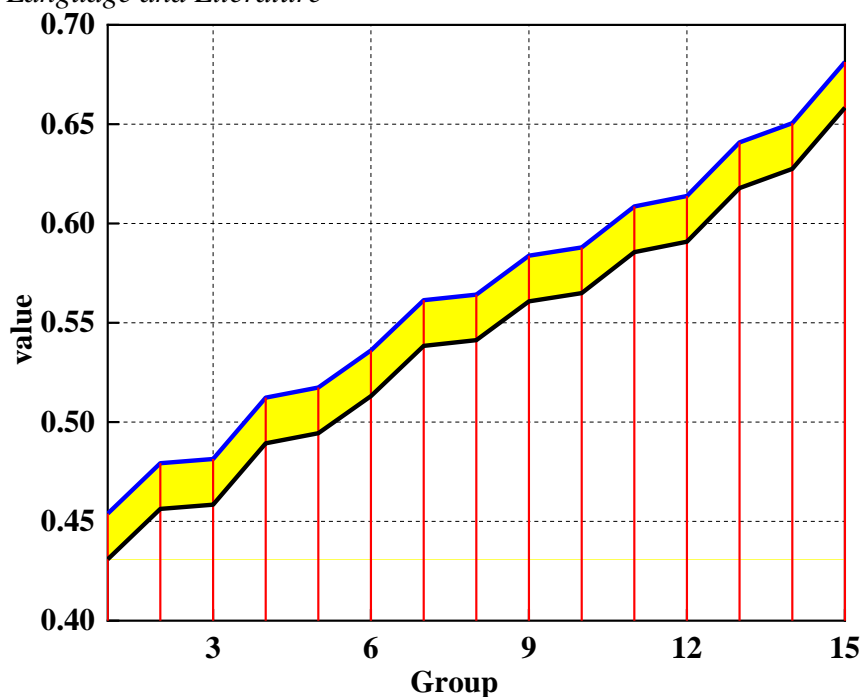

Both in terms of the numerical values of emotional features and the trends of emotional feature transformation, the CNN and GRU methods exhibit superior predictive performance. This is also conducive to the realization of an intelligent classroom for English Language and Literature.

5. Conclusion

The English Language and Literature course has always been a compulsory subject in English majors. Through the study of English language and literature, students can gain a deeper understanding of the political, economic, and social

development of English-speaking countries. This is a more advantageous way of comprehending English compared to other methods. The study of English language and literature holds an equal importance as that of ancient Chinese literature. Traditional teaching methods relying on textbooks and PowerPoint presentations are no longer suitable for English language and literature instruction. English language and literature is a relatively dry subject, often leaving students feeling bored and diminishing their learning efficiency and interest in the subject. With the continuous advancement of science and technology and the increasing demand for English proficiency, it has become necessary to implement an intelligent mode of teaching for English language and literature.

This study utilized CNN and GRU methods to investigate the predictive performance of three features in an intelligent English language and literature course. Firstly, the study explored the significance of GRU technology in realizing intelligent English language and literature courses. While the predictive errors for the three features—student speech, English language and literature sentence patterns, and English language and literature emotions—are within acceptable ranges, these errors are relatively large. The maximum error exceeds 3%, which is unfavorable for achieving an intelligent English language and literature classroom and indicates that feature extraction for English language and literature is incomplete without the use of GRU methods. When employing the GRU algorithm in the study, the predictive errors for all three features notably decreased. The most substantial reduction was observed in student speech features, where the error decreased from approximately 2% to 1.21%. This underscores the importance of the GRU algorithm in extracting English language and literature features. Despite the reduction, the predictive error for emotional features in English language and literature remains relatively higher. Nevertheless, this error is uniformly distributed, which is beneficial for the implementation of an intelligent English language and literature teaching environment.

This study has provided an intelligent English literature teaching approach; however, its scope and generalization are constrained by the quantity and range of the dataset, as well as the limitations of the distribution of optimal weights and biases identified in this study. As society evolves and data continues to update, the types and quantities of data encountered in English literature teaching processes will exhibit significant variations. To enhance the scope and generalization

capacity of deep learning models for intelligent English teaching, it is imperative to continuously enrich the types and quantities of datasets. In terms of application scope, this study solely selected three characteristics from English literature teaching, while there are likely more correlations in practical teaching scenarios. To broaden the application scope of intelligent English literature deep learning models, the inclusion of various types of features is necessary. The deep learning framework designed in this study can be extended to further enrich the distinctive features of English literature teaching. Regarding deep learning algorithms, this study employed shallow CNN and GRU models. However, there are considerable limitations for large-scale intelligent English literature teaching. As this study solely explored the feasibility of deep learning models in English literature teaching, it was also constrained by the capacity of the computer's graphics card. To enhance the application capabilities of intelligent algorithms in English literature teaching, it is essential to further increase the depth of the CNN and GRU networks. In summary, it necessitates the augmentation of dataset quantities, feature varieties, application scope of intelligent algorithms, and the depth of algorithms.

References

- Al-Obaydi, L. H., & Pikhart, M., Shakki, F. (2023). Digital gaming as a panacea for incidental L2 acquisition in an EFL context. *Applied Research on English Language*, 12(1), 73–94. <https://doi.org/10.22108/are.2022.135344.2001>
- Al-Obaydi, L. H., Shakki, F., Tawafak, R. M., Pikhart, M., & Ugla, R. L. (2023). What I know, what I want to know, what I learned: Activating EFL college students' cognitive, behavioral, and emotional engagement through structured feedback in an online environment. *Frontiers in Psychology*, 13: 1083673. <https://doi.org/10.3389/fpsyg.2022.1083673>
- Arsyad, S., & Adila, D. (2018). Using local style when writing in English: the citing behaviour of Indonesian authors in English research article introductions. *Asian Englishes*, 20(2), 170–185. <https://doi.org/10.1080/13488678.2017.1327835>
- Bai, L. P. (2020). Joint patronage in translating Chinese literature into English A case study on the Chinese Literature Overseas Dissemination Project. *Babel-Revue Internationale De La Traduction-International Journal of Translation*, 66(4-5), 765–779. <https://doi.org/10.1075/babel.00171.bai>
- Chen, M. Y., & Yuan, Z. C. (2022). Teaching mode of English language and literature based on artificial intelligence technology in the context of big data. *Mobile Information Systems*, 2022, 1275368. <https://doi.org/10.1155/2022/1275368>
- Dalvai, M. (2019). Translating literature into English in the twenty-first century Opportunities and challenges. *Orbis litterarum*, 74(6), 392–410. <https://doi.org/10.1111/oli.12242>
- Davies, L. M., & Buzacott, L. (2022). Rethinking literature, knowledge and justice: selecting 'difficult' stories for study in school English. *Pedagogy Culture and Society*, 30(3), 367–381. <https://doi.org/10.1080/14681366.2021.1977981>
- Derakhshan, A., & Fathi, J. (2023). Grit and foreign language enjoyment as predictors of EFL learners online engagement: The mediating role of online learning self-efficacy. *The Asia-Pacific Education Researcher*. <https://doi.org/10.1007/s40299-023-00745-x>
- Derakhshan, A., & Shakki, F. (2019). A critical review of language teacher education for a global society: A modular model for knowing, analyzing, recognizing, doing,

- and seeing. *Critical Studies in Texts and Programs in Human Sciences*, 19(6), 109–127. <https://doi.org/10.30465/crtls.2019.4378>
- Derakhshan, A., & Shakki, F. (2020). [Review of the book *Worldwide English Language Education Today: Ideologies, Policies, and Practices*, by A. Al-Issa & S. A. Mirhosseini]. *System*, 90. <https://doi.org/10.1016/j.system.2020.102224>
- Ding, L., Hong, Z. (2023). On the relationship between pre-service teachers' sense of self-efficacy and emotions in the integration of technology in their teacher developmental programs. *Asia-Pacific Edu Res.* <https://doi.org/10.1007/s40299-023-00758-6>
- Dunn, M. B., & Johnson, R. A. (2020). Loss in the English classroom: A study of English teachers' emotion management during literature instruction. *Journal of Language and Literacy Education*, 16(2), 5–10.
- Fu, J., & Wang, Y. (2022). Inspecting EFL teachers' academic literacy development in multilingual contexts: A global vision. *Heliyon*, <http://doi.org/10.1016/j.heliyon.2022.e12143>.
- Genova, M. M. (2019). Designing an effective digital learning environment for teaching English through literature: The learning experience of Bulgarian students. *Journal of e-learning and knowledge society*, 15(2), 121–132. <https://doi.org/10.20368/1971-8829/1592>
- Guan, H. Y. (2018). Cross-cultural awareness teaching in English literature education. *International Conference on Education, Psychology, and Management Science*, 2018(1), 93–97. <https://doi.org/10.25236/icepms.2018.019>
- Guo, K. Y., Sui, L. J., & Qiu, J. T. (2017). Angel-Eye: A complete design flow for mapping CNN onto embedded FPGA. *IEEE Transactions on Computer-aided Design of Integrated Circuits and Systems*, 37(1), 35–47. <https://doi.org/10.1109/TCAD.2017.2705069>
- Guo, Y., Wang, Y., & Ortega-Martín, J. (2023). The impact of blended learning-based scaffolding techniques on learners' self-efficacy and willingness to communicate. *Porta Linguarum*, 40(2): 253-273. doi: <https://doi.org/10.30827/portalin.vi40.27061>
- Hart, J. L. (2019). Poetry in English as comparative and world literature. *University of Toronto Quarterly*, 88(2), 229–245. <https://doi.org/10.3138/utq.88.2.10>

- He, C. M., & Kang, H. Y. (2019). An effective classifier based on convolutional neural network and regularized extreme learning machine. *Mathematical Biosciences and Engineering*, 16(6), 8309–8321. <https://doi.org/10.3934/mbe.2019420>
- Hu, N., Liu, S. Y., & Liu, L. Y. (2022). The educational function of English children's movies from the perspective of multiculturalism under deep learning and artificial intelligence. *Frontiers in Psychology*, 2022(2), 759094. <https://doi.org/10.3389/fpsyg.2021.759094>
- Hu, L., & Wang, Y. (2023). The predicting role of EFL teachers' immediacy behaviors in students' willingness to communicate and academic engagement, *BMC Psychology*, 11(1), 1–10.
- Li, J. (2018). Contrastive analysis of English literature comparative literature based on Bayesian clustering approach to big data. *Cluster Computing-The Journal of Networks Software Tools and Applications*. 22(3), 57031–57037. <https://doi.org/10.1007/s10586-018-2123-1>
- Marinero, I. (2020). Using pedagogical stylistics to teach world literature in English in Italian upper secondary schools: Going beyond traditional English literature syllabi. *Academic Journal of Modern Philology*, 10(3), 163–182.
- Pedersen, M., Verspoor, K., & Jenkinson, M. (2022). Artificial intelligence for clinical decision support in neurology. *Brain communications*, 2(2), 96. <https://doi.org/10.1093/braincomms/fcaa096>
- Razavipour, K., Moosavinia, S., & Atayi, S. (2018). Construct ambiguity and test difficulty generate negative washback: The case of admission test of English literature to graduate programs in Iran. *International Journal of Instruction*, 11(4), 717–732. <https://doi.org/10.12973/iji.2018.11445a>
- Rivera, J. P. (2018). The reception of literature in English in the Spanish scope: creation of a corpus from the analysis of educational publishing houses. *Ogigia-revista electronica de estudios hispanicos*, 23(10), 49–68.
- Sargsyan, M. S., & Zimina, E. S. (2021). Reimagining literature in the English language teaching context in the Russian and Armenian higher education. *Journal of Language and Literary Studies*, 35(12), 137–155. <https://doi.org/10.31902/flj.35.2021.7>

- Shakki, F. (2022). Iranian EFL students' L2 engagement: The effects of teacher-student rapport and teacher support. *Language Related Research*, 13(3), 175–198. <https://doi.org/10.52547/LRR.13.3.8>
- Shakki, F. (2023). Investigating the relationship between EFL learners' engagement and their achievement emotions. *Porta Linguarum An International Journal of Foreign Language Teaching and Learning*, 40(2), 275–294. <https://doi.org/10.30827/portalin.vi40.27338>
- Torrallbo, C. J. (2021). A study of the English-to-Spanish translations published in the first issue of the second phase of the journal *Contico*. *Hermeneus*, 22(2), 415–460. <https://doi.org/10.24197/her.22.2020.415-460>
- Vilaco, F. D., & Guirau, M. C. (2019). Questions about the teaching of English literature for English majors at ufms and ifsp: The experience of working on the syllabi. *Revell-revista De Estudos Literarios Da Uems*, 3(28), 302–317.
- Wang, Y., & Derakhshan, A. (2023). Enhancing Chinese and Iranian EFL students' willingness to attend classes: The role of teacher confirmation and caring. *Porta Linguarum*, 39(1), 165–192. <http://doi.org/10.30827/portalin.vi39.23625>
- Wang Y., Derakhshan A., & Pan, Z. (2022a). Positioning an agenda on a loving pedagogy in second language acquisition: Conceptualization, practice, and research. *Frontiers in Psychology*, 13, 894190. <https://doi.org/10.3389/fpsyg.2022.894190>.
- Wang, Y., & Derakhshan, A., Rahimpour, H. (2022b). Developing resilience among Chinese and Iranian EFL teachers: A multi-dimensional cross-cultural study. *Journal of Multilingual and Multicultural Development*. <https://doi.org/10.1080/01434632.2022.2042540>.
- Wang, Y., & Hemchua, S. (2022). Can we learn about culture by EFL textbook images?: A semiotic approach perspective. *Language Related Research*, 13(3), 479–499. <https://doi.org/10.29252/LRR.13.3.18>
- Wang, Y. (2023). Probing into the boredom of online instruction among Chinese English language teachers during the Covid-19 pandemic. *Current Psychology*, <https://doi.org/10.1007/s12144-022-04223-3>.
- Wang, Y., Pan, Z. W., & Wang, M. Z. (2023a). The moderating effect of participation in online learning on EFL teachers' teaching ability. *Heliyon*,

9(3)e13890, 1–12. <https://doi.org/10.1016/j.heliyon.2023.e13890>.

Wang, Y., Derakhshan, A., Pan, Z., & Ghiasvand, F. (2023b). Chinese EFL Teachers' Writing Assessment Feedback Literacy: A Scale Development and Validation Study. *Assessing Writing*, 56, 1–16. <https://doi.org/10.1016/j.asw.2023.100726>.

Wang, Y. L., Wang, Y. X., Pan, Z. W. & Ortega-Martín, J. L. (2023c). The predicting role of EFL students' achievement emotions and technological self-efficacy in their technology acceptance. *The Asia-Pacific Education Researcher*, [https://doi: 10.1007/s40299-023-00750-0](https://doi.org/10.1007/s40299-023-00750-0).

Wang, Y. L. & Pan, Z. (2023). Modelling the effect of Chinese EFL teachers' self-efficacy and resilience on their work engagement: A structural equation modeling analysis. *SAGE Open*. <https://doi.org/10.1177/21582440231214329>

Wu, H. W., Wang, Y. L., & Wang, Y. S. (2023). What do we know about L2 teachers' emotion regulation? A bibliometric analysis of the pertinent literature. *Forum for Linguistic Studies*, 5(3). <https://doi.org/10.59400/fls.v5i3.2012>.

Yüce, E., Kruk, M., & Derakhshan, A. (2023). Metacognitive knowledge and openness to diversity and challenge among Turkish pre-service EFL teachers: The mediating role of creative self-efficacy. *Thinking Skills and Creativity*. <https://doi.org/10.1016/j.tsc.2023.101386>.

Zhao, G. L. (2018). Research on English literature education practice and dissemination by higher education institutes during the republic of China era. *Educational Sciences-Theory & Practice*, 18(5), 1577–1583. <https://doi.org/10.12738/estp.2018.5.055>

Zhi, R., & Wang, Y. L. (2023). English as a foreign language teachers' professional success, loving pedagogy and creativity: A structural equation modeling approach. *Thinking Skills and Creativity*, <https://doi.org/10.1016/j.tsc.2023.101370>

About the Author

Kehan Du a lecturer at School of International Education, University of Henan Engineering, Henan province, China. She has been working as a language teacher in diverse international contexts with a language education background. Her current research is mainly in the area of English Listening and Speaking Teaching and Learning.